



BURR KING MFG. CO., INC

1220 Tamara Lane

Warsaw, MO 65355

www.burking.com

(660)438-8998 • 800-621-2748

Fax (660)438-8991

MODEL 979

INSTRUCTION MANUAL



BURR KING MODEL 979

BELT GRINDER



BURR KING MFG. CO., INC.

1220 TAMARA LANE

WARSAW MO 65355

WWW.BURRKING.COM

(660) 438-8998 ♦ (800) 621-2748

FAX (660) 438-8991

June, 2007

Burr King Manufacturing Company, Inc. warrants the below product to be free in material and workmanship. The period of warranty is 1 year (90 days for vibratory bowls of 20 quart and lesser volume) from the date of purchase. No warranty is provided for products that have been modified, abused, handled carelessly, where repairs have been made or attempted by others, or for freight damage. No warranty is provided for three phase electric motors, controllers, etc. when the motors, controllers are not protected by magnetic starters that were supplied and installed by Burr King Manufacturing Company, Inc. No other warranty, written or verbal is authorized by Burr King Manufacturing Company, Inc.

During the warranty period Burr King Manufacturing Company, Inc (or its authorized suppliers or agents) will replace or repair the below product without charge if the product is found by Burr King Manufacturing Company, Inc. to be defective. To receive warranty services you must contact Burr King Manufacturing Company, Inc. and receive authorization fir warranty service. Unless otherwise authorized by Burr King Manufacturing Company, Inc. Products (see * below) must be returned to the factory to receive warranty service.

*Motors, speed controllers, and certain other accessories are warranted by their respective manufactures. To receive warranty service on these items you must contact a brand label service center that supports the product in need of service. Burr King Manufacturing Company; Inc. will assist you in locating a service center.

For the first thirty days after purchase, and when Burr King Manufacturing Company, Inc. authorizes warranty service, we will pay normal and necessary surface freight charges both ways (except for items in *). After thirty days the customer is responsible for all freight charges. Where possible Burr King Manufacturing Company, Inc. may elect to make on site service and/or repairs necessary to return the product to serviceable condition.

To assure prompt warranty service it is necessary that you complete and return the below warranty information to Burr King Manufacturing Company, Inc. please **FAX** or **MAIL** at your convenience.

Product model: _____ Serial number: _____
Date Purchased: _____ Purchased from: _____
Address: _____ City: _____ State/Prov: _____ Postal code _____

Your company name: _____
Address: _____ City: _____ State/Prov: _____ Postal code _____
Phone: _____ Fax: _____ Email: _____
Your name: _____ Title: _____

How did you learn about Burr King products?

Trade show ___ Web ___ Industrial Distributor ___ Advertisement ___ Other _____ Which one: _____

What is the intended use of this product? _____

Please indicate the general work types performed at your company, check all that apply:

Fabrication ___ Machining ___ Casting ___ Molding ___ Welding ___ Finishing ___ Assembly ___ Research ___ Other ___

Please indicate the primary product focus of your company; check all that apply.

Aircraft/Missile ___ Automotive ___ Contract machine ___ Contract Fabrication ___ Agricultural ___ Maintenance ___ Recreational ___
Job shop ___ Foundry ___ Construction ___ Arts ___ Orthopedic ___ Dental ___ Medical ___ Other _____

Please tell us what we can do to improve our products:

May we contact you? Yes ___ No ___

Thank you for purchasing Burr King products!

**REGISTER ONLINE @
WWW.BURRKING.COM**



BURR KING MFG. CO., INC.

1220 TAMARA LANE

WARSAW MO 65355

WWW.BURRKING.COM

(660) 438-8998 • (800) 621-2748

FAX (660) 438-8991

August 29, 2007

LETTER OF AUTHENTICITY

This letter is to certify that all Burr King Belt grinders, Disc grinders, Polishing machines Vibra King Chambers and Bowls are manufactured and assembled in the United States of America.

(Tariff number 847990 criterion A)

A handwritten signature in black ink, appearing to read "Don Mac Carthy".

Don Mac Carthy
President

See our catalog at www.burrking.com

contact us at info@burrking.com



BURR KING MFG. CO., INC.

1220 TAMARA LANE

WARSAW MO 65355

WWW.BURRKING.COM

(660) 438-8998 ♦ (800) 621-2748

FAX (660) 438-8991

February 2005

OPERATOR, and OPERATING AREA SAFETY

Subject equipment includes Grinders, buffers, polishers, and other rotating equipment. Serious injury or death may occur if minimum safety precautions are not understood, and obeyed by operators and those other persons who may be in the immediate vicinity of the subject equipment. Persons who operate, or are in the immediate vicinity of the subject equipment must be properly trained in, and use, minimum safety precautions and procedures for such machinery.

Minimum safety requirements to operate, or work in the immediate vicinity subject equipment:

1. Read and understand all operating instructions, manuals, labels, and other information provided with the equipment.
2. Install the equipment according to manufacturer's instructions.
3. Securely bolt the equipment to a rigid, structurally sound mounting surface.
4. Use and wear proper eye and face protection.
5. Use and wear proper protection for the body, hands, fingers, feet, and legs.
6. Review and understand all machine guards, adjustments, and points of exposure to potential injury.
7. Do not remove, tamper with, or otherwise alter, equipment guards, and other safety features.
8. Insure the machine is adjusted, and remains adjusted according to manufacture's requirements.
9. Maintain the equipment in good operating condition.
10. Have another person who is knowledgeable in proper and safe operation of the subject equipment demonstrate proper and safe operation to all operators, and to those persons who might be in the immediate vicinity of the subject equipment.
11. Use work piece holding devices when ever possible that diminish the possibility that persons will come in contact with moving machine pieces, or spark/debris output from the machine.
12. Use spark and debris arresting apparatus. Such apparatus should be connected to the machine so as to contain dust and debris that is generated, and to suppress sparks thereby limiting human inhalation risk, and the risk of fire or explosion.
13. Use appropriate inhalation apparatus to protect person from ingestion and/or inhalation of sparks, debris, smoke, particulates, etc.
14. Avoid mixing different metals, alloys, and materials. To mix such materials might create a fire or explosion hazard.
15. Protect persons from work pieces, particulates, etc. that could be forcibly ejected from the machine. For example, a buffing wheel or grinding belt can "grab" a work piece while the work piece is being buffed, polished, ground, or otherwise conditioned, resulting in forcible ejection toward the operator or those in the vicinity of the machine. The use of leather aprons, gloves, and eye shields are examples of protective gear that may be effective. In general do not grind, buff, or otherwise engage the traveling belt, wheel, or disc surface with the work piece pointing into the direction from which the belt, wheel, or disc is traveling. However, if you choose to do so be aware the work piece may lodge in the traveling belt, wheel, or disc and be forcibly, and dangerously ejected.
16. Do not operate this machine if the gap (nip point) between a moving belt, wheel or disc and the work support surface exceeds 1/8 inch.
17. Do not operate this machine if the gap between the moving abrasive belt, disc or wheel and the adjacent face

page 1 continued on next page

See our catalog at www.burrking.com

Contact us at info@burrking.com

Continued from page 1

of the work rest (or table) will permit passage of the work piece through the gap (nip point). Note, however, that certain alloys such as titanium may create conditions where grinding debris can accumulate in a tight gap creating a potential fire hazard. **When in doubt consult with your safety officer.** Failure to observe this warning may result in the work piece or other item being caught in this gap, and/or being forcibly ejected. Failure to heed this warning may cause serious bodily harm to the operator and/or bystanders. **NEVER USE THIS EQUIPMENT IF YOU ARE NOT PROPERLY TRAINED IN ITS OPERATION and/or SAFE USE! IF IN DOUBT STOP and ASK FOR GUIDANCE!**

18. Never position the work rest table at an acute angle between the top of the work rest table and the moving belt or wheel. Doing so will create “nip point” that can cause serious injury should an operator body part become entangled (pulled into) the nip point created by this acute angle.

19. Do not operate the equipment, or allow others to operate the equipment without proper training in these and other rotating machinery safety requirements.

20. Do not perform maintenance on the equipment unless you are fully qualified to do so, and understand all necessary safety and operating requirements.

21. Do not leave the machine unattended while it is running.

22. Correct equipment or safety problems immediately. Do not operate the equipment when it requires maintenance, or correction.

23. Install and use high quality abrasive belts, wheels, discs, media, etc., as appropriate to your machine. Understand and follow the operating requirements provided by the manufacturer of these materials.

Rotational Speed Warning, Contact Wheels

Scope: Contact wheels manufactured by Burr King Manufacturing Company, Inc., which have rubber or urethane tires. Examples include but are not limited to stock codes 202, 302, 402, 502, 702, 802, 902, 1002, 1202 and variants. Variants have stock codes that begin with the base number; i.e. 802-S-55 is an 802 variant.

Users are warned not to exceed the below listed revolutions per minute (RPM) on the subject wheels. Failure to heed this warning may lead to tire de-bonding, fragmentation, or other mechanical failure. Such failures may cause serious personal injury to operators or bystanders, and/or cause property damage. All Burr King products are warranted for various time periods to be free of material and/or workmanship defects. Burr King Manufacturing Companies standard warranty policy is summarized as follows for contact wheels. 1 year from date of purchase if mounted on a Burr King machine purchased on the same date or 90 days if purchased as a spare or replacement part. Our warranty does not apply to wheels that are mounted on products not manufactured by Burr King Manufacturing Company, Inc. Users who mount Burr King manufactured contact wheels on product not manufactured by Burr King Manufacturing Company, Inc. do so at their own risk and assume all liability for having so mounted the contact wheel(s).

Remember good safety practice demands guarding to protect operators and bystanders from wheel failure and/or debris. Never use the subject contact wheels without proper guarding that meets commonly accepted safe practice. See OSHA, U/L, CSA, CE, ISO and other respected safety standards.

Stock code	
Contact Wheel	Maximum Safe RPM
202, 302	10000
402, 502, 702 802	4400
902, 1002	2200
1202	1600

Continued from page 2

Occupational Noise Exposure

Burr King products produce levels of noise consistent with their intended purposes. The level and spectral content of noise produced is dependent on the product type, the degree that the product is maintained in proper operating condition, the abrasive/media and accessories used, the specific application, and the surrounding environment. Noise levels produced by various Burr King grinders and polishers, as measured at the Burr King factory, range from 80 to 93 decibels. Product operators and persons in the immediate product vicinity should be protected from excessive noise does levels as prescribed in OSHA regulation 29, piece 1910.95 titled "Occupational Noise Exposure".

ROTATING EQUIPMENT CAN BE DANGEROUS TO OPERATORS AND THOSE WHO MAY BE IN ITS IMMEDIATE OPERATING VICINITY. IT IS THE ABSOLUTE AND DIRECT RESPONSIBILITY OF PURCHASERS, MANAGERS, AND OPERATORS OF THIS EQUIPMENT TO UNDERSTAND AND OBEY THE FOREGOING MINIMUM OPERATING SAFETY REQUIREMENTS. IF YOU HAVE QUESTIONS OR SAFETY CONCERNS REGARDING OPERATING THE SUBJECT EQUIPMENT PLEASE CALL YOUR AUTHORIZED BURR KING DISTRIBUTOR, OR BURR KING MANUFACTURING AT 1-800-621-2748. YOUR SAFETY IS OUR FOREMOST CONCERN!

Burr King Manufacturing disclaims any and all responsibility for injuries, damage, loss of income, or other adverse consequence as might be incurred by purchasers, managers, and operators of this equipment.

Page 3 is last page



BURR KING MFG. CO., INC.

1220 TAMARA LANE

WARSAW MO 65355

WWW.BURRKING.COM

(660) 438-8998 ♦ (800) 621-2748

FAX (660) 438-8991

October 2001

OPERATING INSTRUCTIONS FOR THE MODEL 979 TWO WHEEL BELT GRINDER

The model 979 two-wheel belt grinder provides heavy-duty service for contact wheel, platen, and supported work grinding using a 3 x 79 inch belt track.

Prior to operating the model 979 please take time to do the following:

1. Insure that you have received all of the items that you ordered. Compare the packing slip with your purchase order, and of course with the physical items received.
2. Verify that there is no obvious shipping damage. If shipping damage is discovered notify the freight carrier of your intention to file a freight damage claim. They will assist you.
3. Verify that the AC power that is identified on the machine as received matches the AC power that you intend to operate the machine with. Do not modify the machine's wiring without first contacting your distributor and/or Burr King Manufacturing.
4. Do not modify or defeat any AC wiring safety feature. In example, do not remove the grounding pin on the AC plug.
5. Verify that you have received a warranty card, parts lists, catalog, and Operator, and Operating Area Safety Instructions.
6. Complete the warranty card and return it to Burr King Manufacturing.
7. Verify that the belt guard for the machine is in place and functional.
8. Insure that the grinder is located in an area that provides clear access to the machine such that operators have safe and unobstructed access to the machine. The work place should be free from floor obstructions, trip points, and other faults that may reduce operator safety.
9. Burr King recommends that all three-phase installations include a magnetic starter. Magnetic starters protect motors from "single phasing", overheating, etc. thereby reducing the risk of damage to the equipment and/or fire hazard to your facility.
10. Insure that the model 979 AC power source is properly sized, and properly fused. You should consult a competent electrician, or you may call Burr King Manufacturing for guidance.

Functional operating instructions for the model 979 belt grinder

The model 979 was fully tested and verified to comply with requirements prior to shipping from the factory. No adjustments should be necessary. You should perform the following steps:

1. Securely bolt the machine to the floor. Note that the pedestal base has four holes that are sufficient for ½ inch anchor bolts. Do not use anchor bolts that are less than 3/8 inch in diameter and/or that do not provide for at least 2 ½ inches of depth grip in secure concrete.
2. With the machine securely bolted to the floor point connect the AC power to its source.
3. Adjust the work support and work support arm to the desired position or remove them if they are not required for your grinding mode of choice. If you use the work support table take care that the gap between the face of the abrasive belt and the work support is not greater than 1/8 inch.
4. To install or remove an abrasive belt push the lever on the top of the machine to its rear most position until the keeper latch secures the lever in its rear most position. Install or remove the belt. Gently push the belt tension lever to the rear and lift the latch. Allow the lever to move forward. The abrasive belt is tensioned automatically by the coil springs that are integral to the motor base.

5. Assure the abrasive belt is aligned on the rear wheel and the contact wheel. The belt should glide across the platen.
Start the machine. The belt should run forward the floor across the face of the contact wheel. If the belt runs in the opposite direction you must reverse the direction of the electric motor. **FIRST DISCONNECT THE MACHINE FROM ITS AC POWER SOURCE. A COMPETENT ELECTRICIAN SHOULD PERFORM ALL ELECTRICAL WORK ON THE MODEL 979.** For three-phase motors reverse any two incoming power hot lines, for single-phase motors consult the motor label.
6. If the abrasive belt does not remain centered on the contact wheel while the belt is moving use the tracking adjustment right side of the machine to track the belt.. Generally, it should require less than one turn to track the belt back to center.
7. The contact wheel height is adjustable at least 4 inches up or down from nominal. This adjustment is made dependent of the model of machine that you purchase. Assure the machine is turned off and the belt has stopped movement. Loosen the securing bolt on the right side of the pedestal under the machine head. If the machine has a wheel under the head rotate the wheel as required to adjust the contact wheel height. If there is no wheel lift or depress the grinding head to the desired position and secure the locking bolt.

Grinding modes

1. Contact wheel: Grind on the contact wheel for heavy stock removal. Always pass the work piece downward across the outer diameter of the contact wheel.
2. Supported work: Use the work support to support your work piece against the contact wheel.
3. Platen: Raise the platen door and rest it to the rear of the machine. Rest your work piece against the platen and to the front of the platen such that the frame of the grinder braces the work piece. The work support is apparent immediately to the front of the platen. Remember that platen grinding consumes a great deal of horsepower since the work part is “pinching” the belt to the platen. Also note that platen grinding creates much more heat than do other grinding modes where the belt is not pinched to a stationary surface. This extra generation of heat can shorten abrasive belt life and raise work piece temperature to levels that may be detrimental to the part.

Maintenance for the model 979

FIRST DISCONNECT THE MACHINE FROM ITS AC POWER SOURCE.

* Every thirty days apply light machine oil to contact wheel pivot point and the tracking control lever screw. Two drops of oil is sufficient.

* Daily vacuum or otherwise remove dust and debris build-up from the machine and the machine belt track. There are no other maintenance actions required. All bearings are sealed for life and require no additional lubrication.

Remember for operator safety and the continued effectiveness of your model 979:

Do not defeat the safety guards and other safety provisions of the model 979.

Do not operate the model 979 with the safety guard open or the contact wheel guard/platen assembly (or internal grinding attachment) removed.

Do not reach inside the safety guards while the machine is running. To do so is hazardous.

Do not use fluids in your grinding process unless your model 979 is designed for liquid operation (NEMA 4, 4X). To do so may create an electrical safety hazard.

Do not use your model 979 to grind/polish explosive materials unless it is equipped with explosion proof electrical devices and motor.

Do not mix alloys in your grinding. To do so may create an explosion/fire hazard.

Do not use stone or vitreous wheels on the model 979. To do so will create an operator safety hazard.

Do use eye, hand, face, arm, leg, feet and body protection that is adequate to protect against flying debris, forcibly ejected work pieces, broken abrasive belts, etc.

Do train operators and others in safe operating practices.

Post these or equivalent instructions such they are available for ready operator reference.

Burr King Manufacturing can help you with problem solutions, and/or answers to your questions. Please call your Burr King distributor first. If you can not reach satisfactory conclusion please call the Burr King factory, telephone 1-660-438-8998.

See our catalog at www.burrking.com

Contact us at info@burrking.com

M979 SCHEMATIC

BURR KING

1220 TAMARA LANE
WARSAW, MO. 65355

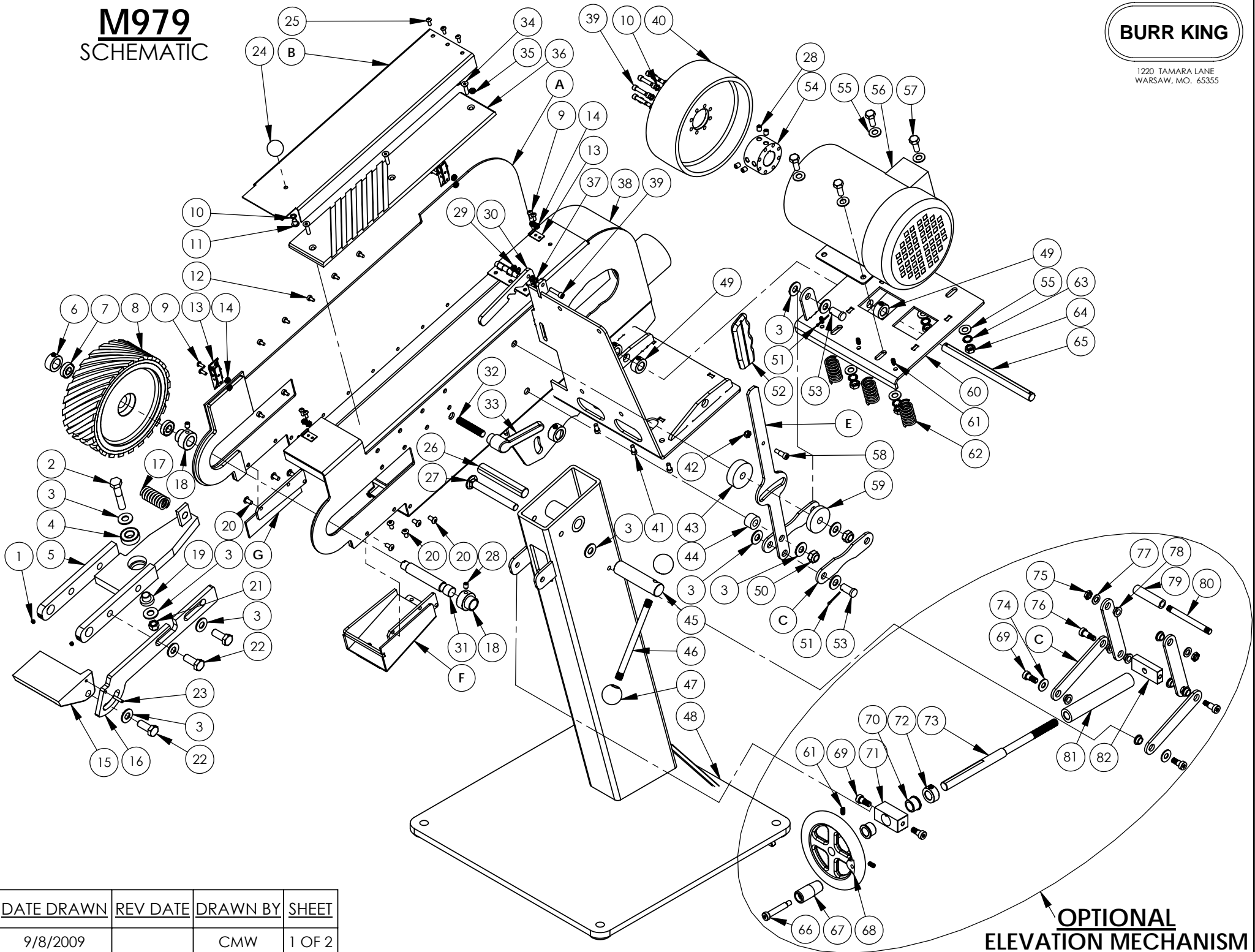

DATE DRAWN	REV DATE	DRAWN BY	SHEET
9/8/2009		CMW	1 OF 2

**OPTIONAL
ELEVATION MECHANISM**



M979			
ITEM NO.	PART NUMBER	DESCRIPTION	QTY.
1	3-0010	SCREW, 1/4-20 x 1/4, SET, CUP	2
2	1-0031	BOLT, 1/2-13 x 2.5, HH, GRD5	1
3	21	WASHER, 1/2, SAE, FLAT, ZINC	12
4	701B	BEARING	1
5	604	WELDMENT, CONTACT WHEEL	1
6	627	COLLAR, 3/4 x 1 1/4 x 9/16	1
7	11-0010	BEARING	2
8	9320	CONTACT WHEEL, 8x3, FORK 90D, S	1
9	24	SCREW, 6-32 x 1/2, MACH	8
10	5-0032	WASHER, 1/4, LOCK, SPLIT	9
11	2-0015	SCREW, 5/16-24 x 3/8 BH	1
12	6-0011	RIVETS, SS, 3/16 x 1/2	7
13	623	LATCH, DRAW	2
14	23	NUT, 6-32, KEP	8
15	622	WORKREST	1
16	661	SUPPORT, WORKREST	1
17	616	SPRING, TRACKING	1
18	699	BUSHING, ECCENTRIC	2
19	638	SPACER, NOSE	1
20	2-0028	SCREW, 1/4-28x1/2 BH	8
21	41	NUT, 1/2-13, NYLOK, ZP STD	1
22	1-0028	BOLT, 1/2-13 x 1 1/4 HH	3
23	6-0001	PIN, 3/16 X 1, ROLL	1
24	660	KNOB, 1/4-20, PLASTIC, BALL	1
25	9	SCREW, 10-24x1/2 BH	3
26	606	ROD, HEAD PIVOT	1
27	1-0029	BOLT, 1/2-13x4.5, GRD5, CARR, PL	1
28	25	SCREW, 5/16-18 X 3/8, SET, SOC	6
29	4-0013	NUT, 1/4-20, KEP	1
30	634	LATCH, TENSION RELEASE	1
31	1602-3M	SHAFT, CONTACT WHEEL	1
32	642	ROD, 1/2-13 ALL THREAD, 3.5"	1
33	624	HANDLE, 1/2-13, BELT TRACKING	1
34	7-0008	SCREW, 1/4-20 x 1, FLAT HD, ALLEN	3
35	14	NUT, 10-24, KEP	3
36	621	PLATEN	1
37	5	WASHER, 960-416 AN	3
38	603	WELDMENT, MAIN HEAD	1
39	30	SCREW, 1/4-20x1 SOC CAP	9
40	625	WHEEL, DRIVE, 8 x 3	1
41	1431	BOLT, 1/4-20 X 1/2 ALLEN, CS	3
42	11B	NUT, 1/4-20, ACORN, CROWN	1
43	629	SPACER, 2OD x 1/2ID, DELRIN	1
44	631	SPACER, 1OD x 1/2ID, DELRIN	1
45	2039	SHAFT, MAIN, TABLE, CLAMP	1
46	2027	ARM, GEARBOX LOCKING	1
47	2049	KNOB, BALL, BLK, PLASTIC	2
48	601	PEDESTAL, 979	1
49	628	COLLAR, 5/8 x 1 1/8 x 1/2	3
50	4-0001	NUT, 1/2-13, JAM, ESNA 21, NYLOK	2

M979			
ITEM NO.	PART NUMBER	DESCRIPTION	QTY.
51	6-0005	PIN, COTTER 1/8 x 1	2
52	636	GRIP, HAND, 3/16 x 1 x 4 3/4	1
53	6-0010	PIN, CLEVIS, 1/2 x 1	2
54	635	HUB, DRIVE, 2.48OD x 1.125ID	1
55	5-0023	WASHER, 3/8 X 7/8, USS	8
56	MOTOR	CALL FACTORY	1
57	1-0001	BOLT, 3/8-16 x 1 HEX HEAD	4
58	2-0039	BOLT, 5/16 x 1/2 SHOULDER	1
59	632	WASHER, 2OOD x 1/2ID, DELRIN	1
60	605	WELDMENT, MOTOR MOUNT	1
61	1445	SCREW, 1/4-20 x 3/8, SET	5
62	626	SPRING, BELT TENSION	3
63	5-0014	WASHER, 3/8, LOCK, INTERNAL STAR	4
64	12B	NUT, 3/8-16, HEX, FULL, GRD 5	4
65	617	ROD, MOTOR MOUNT	1

603 INCLUDES			
ITEM NO.	PART NUMBER	DESCRIPTION	QTY.
A	603S	DOOR, SIDE, 603 GUARD	1
B	603V	DOOR, TOP, 603 GUARD	1
C	615	BAR, ELEVATION, 1 x 3/16 x 7- 3/4	4
D	618	LINK, FLAT, 1 x 3/16 x 8- 1/2	2
E	619	HANDLE, TENSION RELEASE	1
F	653	MOUTH ASSEMBLY	1
G	655	MOUTH ASSEMBLY, DOOR	1

OPTIONAL ELEVATION MECHANISM			
ITEM NO.	PART NUMBER	DESCRIPTION	QTY.
66	2-0021	SCREW, 3/8 x 1 3/4, 5/16-18 x 1/2	1
67	2044	HANDLE, SMALL WHEEL	1
68	2013	WHEEL, HAND, SMALL	1
69	613	BOLT, 3/8 x 5/16, SHOULDER	4
70	2025	BUSHING, OILLITE, FLANGE	2
71	609-1	BLOCK, FRONT ELEVATION	1
72	628	COLLAR, 5/8 x 1 1/8 x 1/2	1
73	607	ROD, ELEVATION	1
74	40	WASHER, 3/8, SAE	2
75	39	NUT, 3/8-24, JAM, ESNA, NTE	2
76	2-0040	SCREW, 1/4-20 x 1 1/2, HH	2
77	17	WASHER, 960-616, AN	2
78	614	BUSHING, FLANGE	8
79	602	SPACER, ELEVATION	1
80	637	SUPPORT, ARM, ELEVATION	1
81	608	TUBE, ELEVATION	1
82	610-1	BLOCK, REAR ELEVATION	1

TITLE	DATE DRAWN	REV DATE	DRAWN BY	SHEET
979	9/8/2009		CMW	2 OF 2



1220 TAMARA LANE
WARSAW, MO. 65355

M979

BASIC DIMENSIONS

NOTE:
- ALL DIMENSIONS
ARE IN INCHES

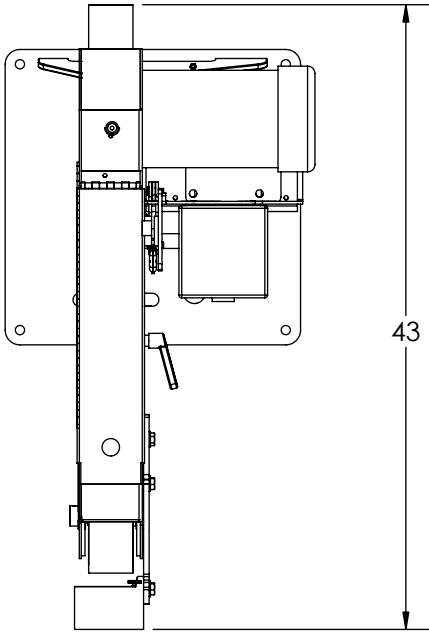

TOP VIEW

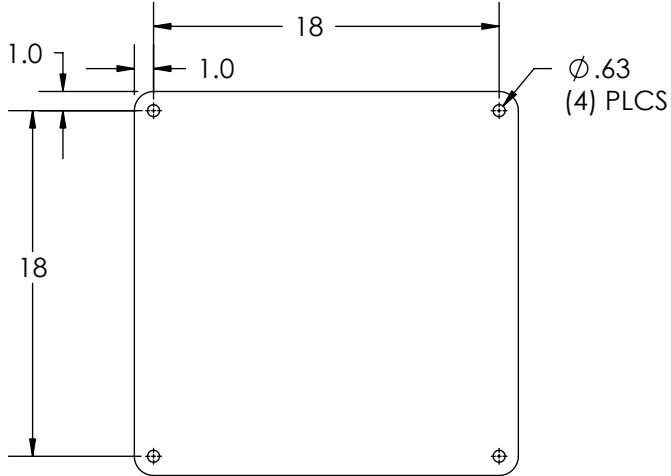

MOUNTING PATTERN

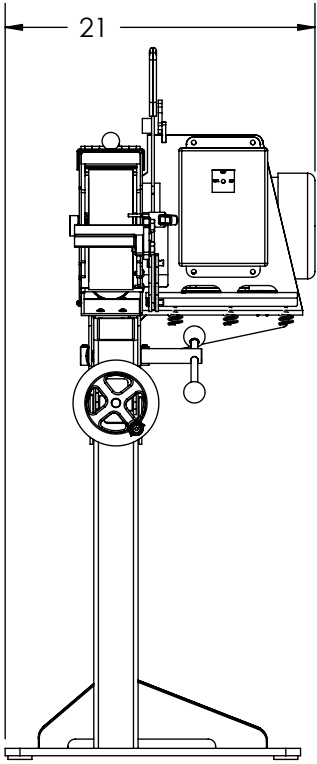

FRONT VIEW

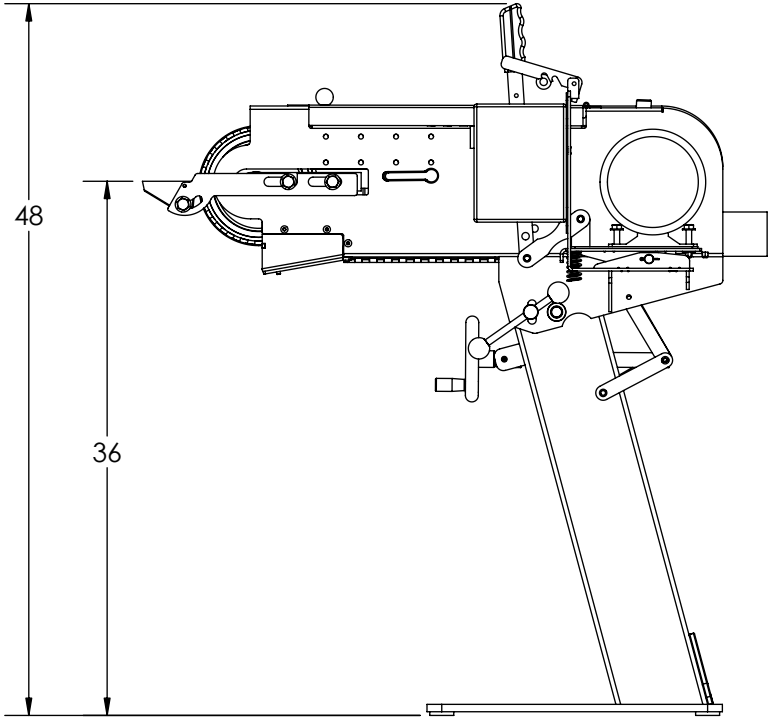

SIDE VIEW

THE DATA CONTAINED HEREIN IS THE SOLE PROPERTY OF BURR KING MFG. CO., INC. REPRODUCTION OR DISTRIBUTION OF THIS DATA IS STRICTLY PROHIBITED WITHOUT CONSENT OF BURR KING MFG. CO., INC.