



# ADVANTAGE



Any Burr King tub or bowl can be used wet or dry

M85

M45

M25

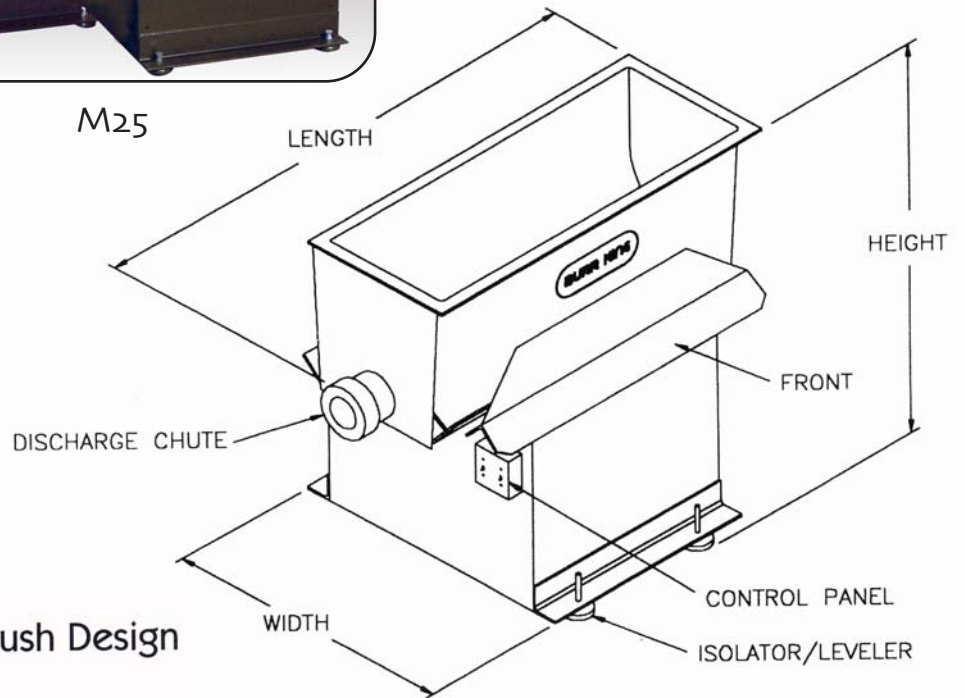

## Vibra KING<sup>®</sup> with Hush Design GENERAL DATA

|                          | M25            | M45           | M85       |
|--------------------------|----------------|---------------|-----------|
| Length max.in.           | 29             | 43            | 48        |
| Width max in.            | 33             | 33            | 36        |
| Height max in.           | 41             | 41            | 45        |
| Total volume cu. ft.     | 2.5            | 4.5           | 8.5       |
| Working volume cu.ft.    | 2.1            | 3.8           | 7.2       |
| Tub width, inside        | 15             | 15            | 20        |
| Tub length, inside       | 20             | 35            | 37        |
| Tub depth, inside        | 16             | 16            | 20        |
| Max. part length, in.    | 19             | 34            | 36        |
| Media load, lbs          | 150            | 250           | 450       |
| Part load, lbs*          | 100            | 225           | 450       |
| Weight max. lbs. (empty) | 390            | 475           | 675       |
| Horse power, standard    | 0.75 (1PH/3PH) | 1.5 (1PH/3PH) | 3.0 (3PH) |

This may vary substantially according to part shapes, material, process times, etc.

ALWAYS WEAR PROTECTIVE EYE, FACE, ARM, LEG AND BODY GEAR WHEN USING ANY GRINDER, POLISHER, BUFFER OR OTHER ROTATING MACHINERY.

BURR KING MANUFACTURING CO., INC. SINCE 1951 1220 TAMARA LANE, WARSAW, MO 65355

(660) 438-8998

(800) 621-2748

FAX (660) 438-8991

www.burrking.com